

EL

ELECTRIC WATER HEATER



Design

The water tank consists of a steel vessel, with a copper lining to protect against corrosion. The outer casing is made from tough plastic-coated galvanised metal.

The pressure vessel is designed and manufactured in accordance with current pressure vessel standards (PED 97/23 EC § 3.3), for a maximum working pressure of 9 bar (0.9 MPa), which is the equivalent to a design pressure (in compliance with current standards) of 10 bar (1.0 MPa).

Thermal insulation is provided by seamless freon-free polyurethane insulation, ensuring excellent thermal performance.

Installation

The water heater is designed for horizontal installation.

In accordance with current norms, the following must be mounted on the cold water side: safety valve (supplied with the water heater), non-return valve, shut-off valve and vacuum valve. The water heater is equipped with a draining device.

When installing the unit, be sure to leave sufficient room (approx. 410 mm) in front of the connection area to facilitate the replacement of any electrical equipment.

Electrical equipment

The water heater is equipped with a terminal block for connecting the supply power cable. The EL 160 and EL 250 have a standard output of 3 kW, but are also available in 6 kW design. The water heater can be connected to 230V (220V)~ single-phase if required, but then the power output is limited to 1.0 kW.

The flanged immersion heater in a Ø 80 mm connection opening allows for simple dismantling, internal inspection and cleaning.

When delivered, the thermostat setting is: 60°C. This can be reset (up to 80°C) by an authorised installer.

Water heaters for houses and apartment buildings

The advantages of EL

effective,
pro-environmental insulation

quick and simple
to install

best performance
and safety



Comfort
from Sweden

Electrical circuit diagram

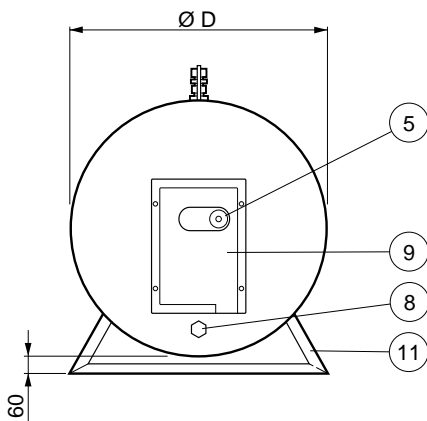
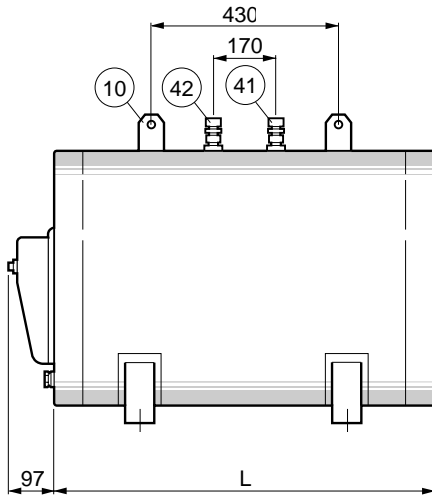

- 4 Terminal block
- 5 Combined thermostat and temperature limiter
- 6 Immersion heater BA 14-112
- 8 Draining device
- 9 Connection area
- 10 Mounting bracket
- 11 Support legs (accessory)
- 13 Combined thermostat and thermal cutout (for 6 kW only)
- 14 Power selector switch
- 15 Terminal block
- 41 Cold water inlet, compression ring coupling Ø 22 mm
- 42 Hot water outlet, compression ring coupling Ø 22 mm

Electrical diagram 3.0 kW

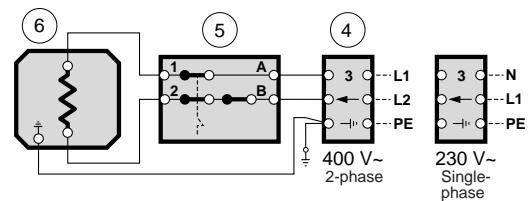

Electrical diagram 6.0 kW

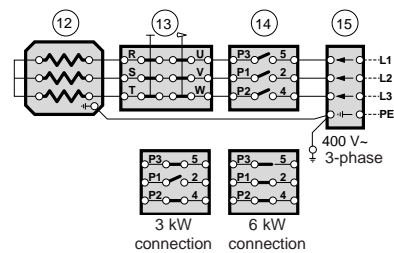

Technical specifications

| Model | | 160 | 250 |
|---------------------------|----------|---------------------------|------------|
| Diameter Ø D | (mm) | 600 | 600 |
| Length L: | (mm) | 840 | 1220 |
| Voltage (standard design) | | 400 V~ two-phase or 230 V | |
| Enclosure class | | IP 24 | |
| Output | (kW) | 1 – 3 | 1 – 3 |
| Fuses | (A) | 6 – 10 | 6 – 10 |
| Heating-up time to 45°C | (hours) | 6.5 2.5 | 10.5 3.5 |
| Heating-up time to 80 °C | (hours) | 13.0 4.5 | 20.5 7.0 |
| Heat content at 80°C | (kWh) | 13.0 | 20.4 |
| Volume | (litres) | 160 | 250 |
| Net weight | (kg) | 80 | 104 |
| Pressure vessel | | PED 97/23 EC § 3.3 | |



Model EL 6 kW 400V~ three-phase can be specially ordered.

We reserve the right to make changes in design and dimensions without prior notice.

NIBE AB
Sweden

Box 14
Järnvägsgatan 40
SE-285 21 MARKARYD

Tel: +46 - (0)433-73 000
Fax: +46 - (0)433-73 190

www.nibe.com

