

Installer manual
SAM 40
Supply air module

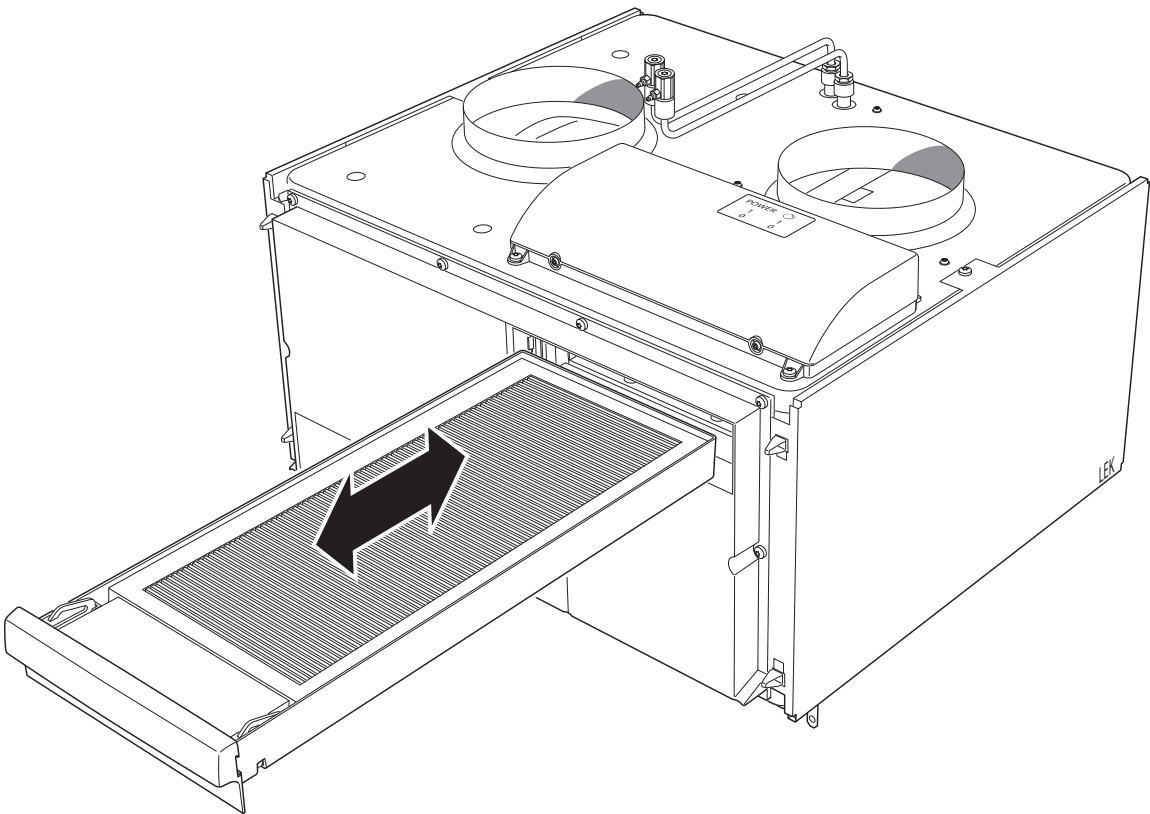
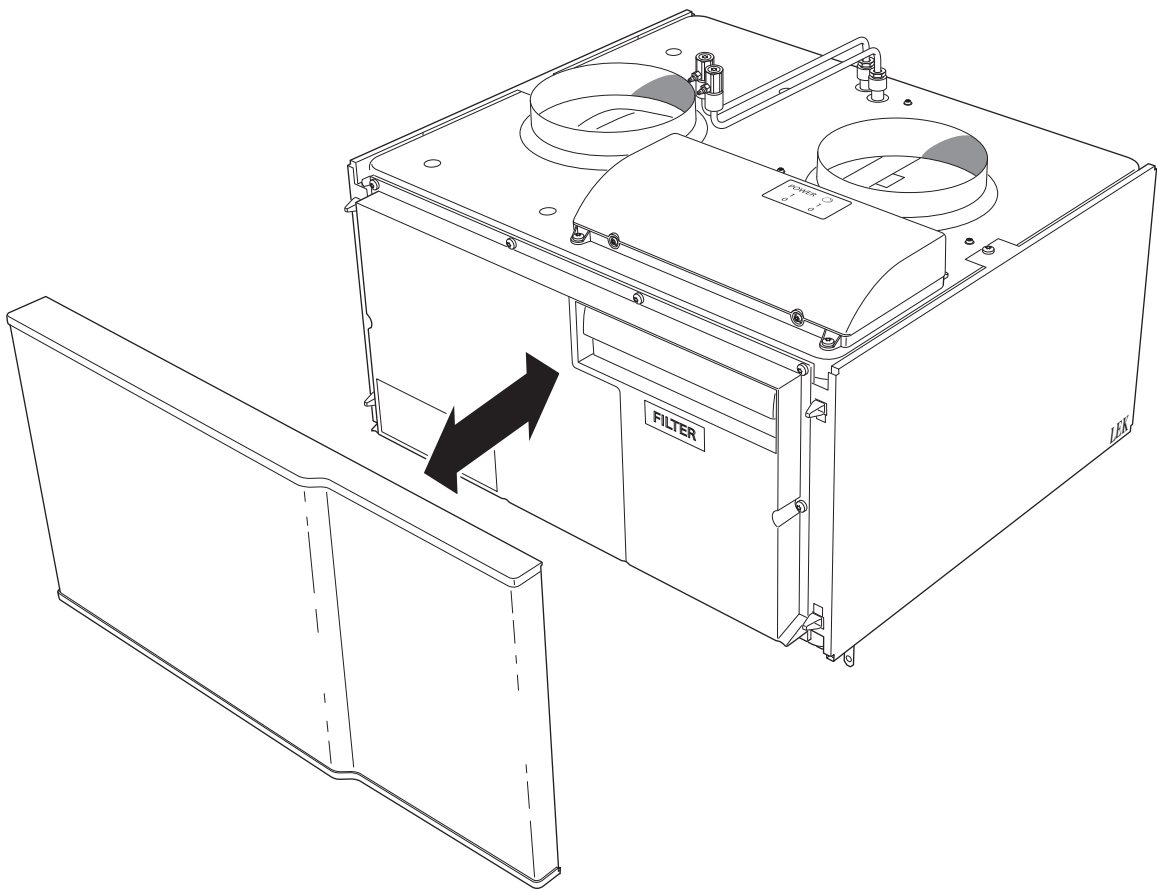

Table of Contents

1 Important information _____	4	10 Technical data _____	23
Safety information _____	4	Dimensions and setting-out coordinates _____	23
General _____	4	Technical specifications _____	24
		Electrical circuit diagram _____	25
2 Delivery and handling _____	6	Item register _____	26
Transport _____	6	Contact information _____	27
Assembly _____	6		
Supplied components _____	6		
Removing the covers _____	6		
3 The design of the supply air module _____	7		
Pipe connections _____	8		
HVAC components _____	8		
Sensors etc. _____	8		
Electrical components _____	8		
Ventilation _____	8		
Miscellaneous _____	8		
4 Pipe and ventilation connections _____	9		
General pipe connections _____	9		
Dimensions and pipe connections _____	10		
Heating medium side _____	10		
Installation alternative _____	13		
General ventilation connection _____	15		
Ventilation flow _____	15		
Adjusting ventilation _____	15		
Dimension and ventilation connections _____	15		
5 Electrical connections _____	16		
General _____	16		
Connections _____	16		
6 Commissioning and adjusting _____	17		
Preparations _____	17		
Filling and venting _____	17		
Start-up and inspection _____	18		
7 Program settings _____	19		
Menu system _____	19		
8 Disturbances in comfort _____	20		
Info-menu _____	20		
Troubleshooting _____	20		
9 Accessories _____	22		

1 Important information

Safety information

This manual describes installation and service procedures for implementation by specialists.

The manual must be left with the customer.

This appliance can be used by children aged from 8 years and above and persons with reduced physical, sensory or mental capabilities or lack of experience and knowledge if they have been given supervision or instruction concerning use of the appliance in a safe way and understand the hazards involved. Children shall not play with the appliance. Cleaning and user maintenance shall not be made by children without supervision.

Rights to make any design or technical modifications are reserved.

©NIBE 2018.



NOTE

If the supply cable is damaged, only NIBE, its service representative or similar authorised person may replace it to prevent any danger and damage.

Symbols



NOTE

This symbol indicates danger to person or machine.



Caution

This symbol indicates important information about what you should observe when maintaining your installation.



TIP

This symbol indicates tips on how to facilitate using the product.

Marking

CE The CE mark is obligatory for most products sold in the EU, regardless of where they are made.

IP21 Classification of enclosure of electro-technical equipment.



Danger to person or machine.



Read the User Manual.

General

Software version

The heat pump must have software version 8432R2 (F370)/3585R2 (F750) or later. Visit www.nibeuplink.com and click on the tab "Software" to download the latest software to your installation or use the enclosed USB memory.

Serial number

The serial number can be found at the bottom left inside the front cover.

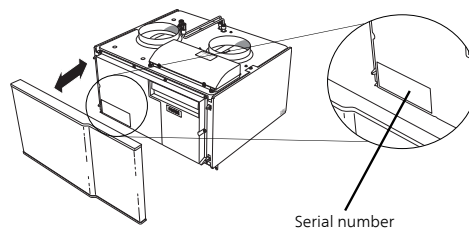

Caution

You need the product's 14 digit serial number for servicing and support.

Recovery



Leave the disposal of the packaging to the installer who installed the product or to special waste stations.

When disposing of the product, its constituent materials and components, e.g. compressors, fans, circulation pumps and circuit boards, must be disposed of at a special waste station or dealer who provides this type of service.

To access the separate components, refer to the section that shows the construction of the product. No special tools are required for access.

Improper disposal of the product by the user results in administrative penalties in accordance with current legislation.

Inspection of the installation

In addition, fill in the page for the installation data in the User Manual.

Current regulations require the supply air module to be inspected before it is put into service. The inspection must be carried out by a suitably qualified person.

✓	Description	Notes	Signature	Date
	Ventilation (page 15)			
	Setting ventilation flow exhaust air			
	Setting ventilation flow supply air			
	Heating medium (page 10)			
	System flushed			
	Accessories bled			
	Check against output and pressure drop diagrams			
	Connected according to outline diagram			
	Electricity (page 16)			
	Supply connected 230 V			
	Connected communication			

2 Delivery and handling

Transport

The supply air module must be transported and stored dry.

Assembly

SAM 40 is mounted free-standing on brackets, alternatively above a VPB 200 (for VPB 300/VPBS 300 installation is carried out using brackets). Noise from the fan can be transferred to the brackets.

- Install the brackets to an outside wall, ideally in a room where noise does not matter, in order to eliminate noise problems. If this is not possible, avoid placing it against a wall behind a bedroom or other room where noise may be a problem.
- Wherever the unit is located, walls to sound sensitive rooms should be fitted with sound insulation.
- Route pipes so they are not fixed to an internal wall that backs on to a bedroom or living room.

Installation area

Leave a free space of 800 mm in front of the supply air module. All service on SAM 40 can be carried out from the front.

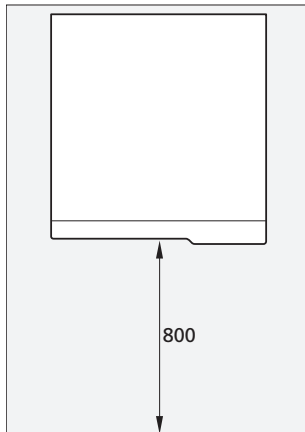

NOTE

Ensure that there is sufficient space (300 mm) above the supply air module for installing ventilation hoses.

Removing the covers

Front cover

1. Remove the service cover by pulling it straight out.

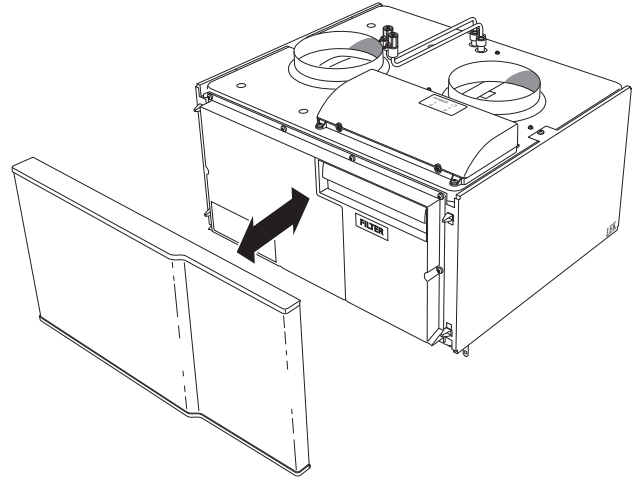

Supplied components



Support bushes
2 x



Vent hose
1 x

3 The design of the supply air module

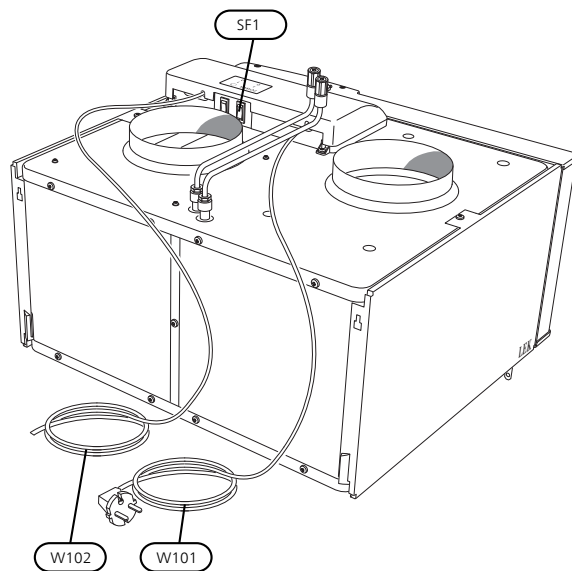
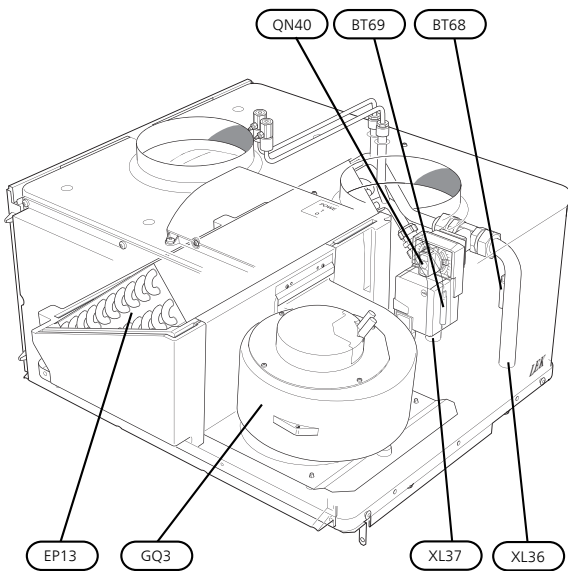
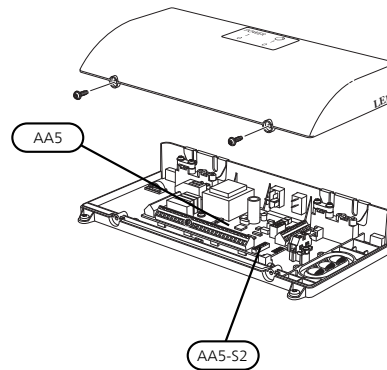
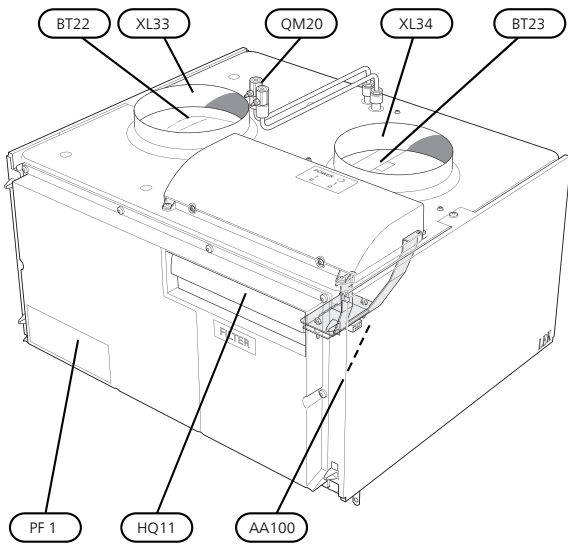

Pipe connections

XL33	Ventilation connection supply air
XL34	Ventilation connection outdoor air
XL36	Connection, heating medium in
XL37	Connection, heating medium out

HVAC components

EP13	Supply air battery
QM20	Venting heating medium
QN40	Control valve heating medium

Sensors etc.

BT22	Temperature sensor, supply air
BT23	Temperature sensor, outdoor air
BT68	Temperature sensor, flow
BT69	Temperature sensor, return

Electrical components

AA5	Accessory card
AA5-S2	Dip switch
AA100	Joint board ¹
SF1	Switch, position 0 - 1, main switch
W101	Cord with connection plug
W102	Communication cable

Ventilation

GQ3	Supply air fan
HQ11	Air filter supply air

Miscellaneous

PF1	Rating plate
-----	--------------

¹ Not visible in the image

Designations in component locations according to standard IEC 81346-1 and 81346-2.

4 Pipe and ventilation connections

General pipe connections

Pipe installation must be carried out in accordance with current norms and directives.



Compatible NIBE heat pumps

SAM 40 is installed together with a compatible exhaust air heat pump from NIBE. You adjust the settings and read off sensor values etc. for the supply air module in the heat pump's display.

Compatible products

- F370
- F750

Symbol key

Symbol	Meaning
	Control valve
	Fan

System diagram



NOTE

External frost protection (outdoor air damper) should be installed in the outdoor air duct, if SAM 40 is installed in a cold climate.

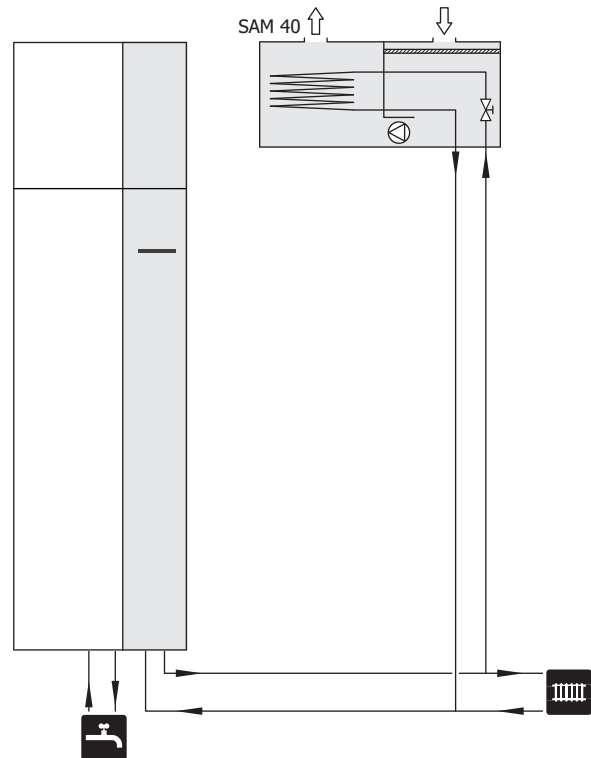

For installation with F750, a buffer vessel (UKV) may be required. See installation alternatives on page 14.

Dimensions and pipe connections

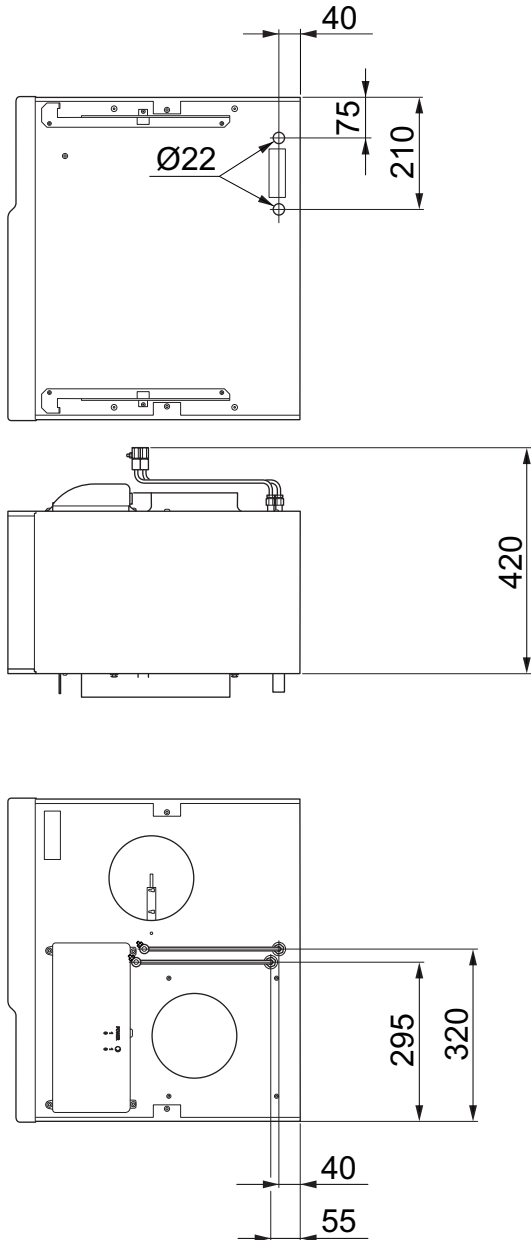

Heating medium side

Dimensioning the system

1. Work from the water temperature at DOT (DVOT).
2. Work from the current supply air flow.
3. Work from the desired supply air temperature, then calculate the output that SAM 40 must give at DOT.
4. Determine the water flow across SAM 40 from the correct output diagram.



NOTE

For supply temperatures that do not appear in any of the diagrams, an estimate (linear interpolation) can be made.

5. Work from the projected pressure drop (at the projected flow) in the waterborne system that is parallel with SAM 40.
6. Check in the pressure drop diagram that the working point is inside the grey working range.
7. Check that the pump capacity from the heat pump is sufficient for both the heating system and SAM 40.

Output transfer to the supply air

Supply temperature 35°C, DUT -10°C

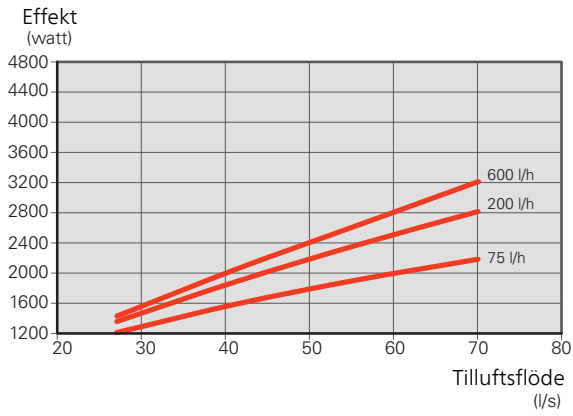

Supply temperature 45°C, DUT -10°C

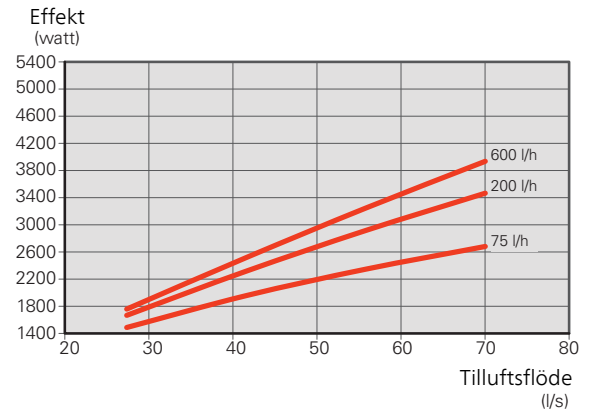

Supply temperature 35°C, DUT -20°C

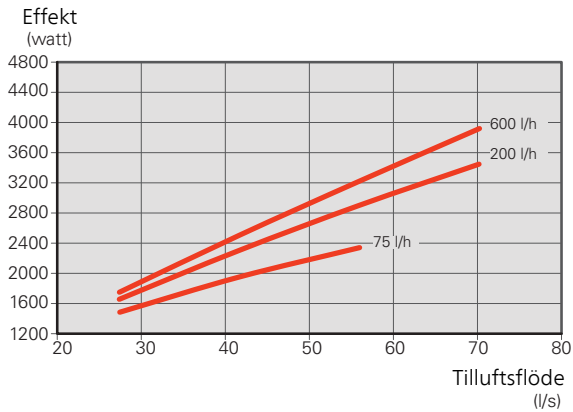

Supply temperature 45°C, DUT -20°C

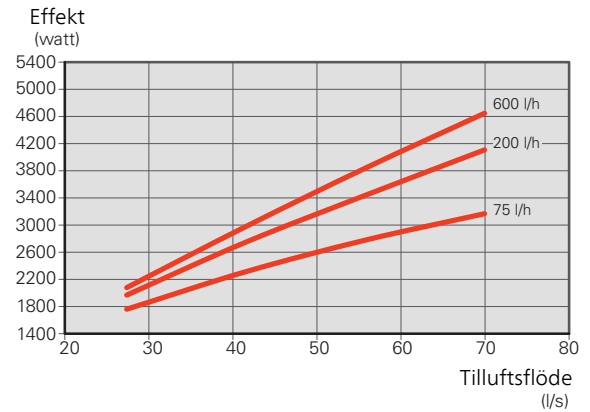

Supply temperature 35°C, DUT -30°C

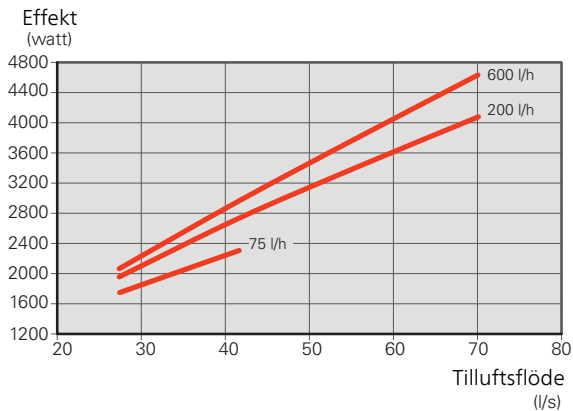

Supply temperature 45°C, DUT -30°C

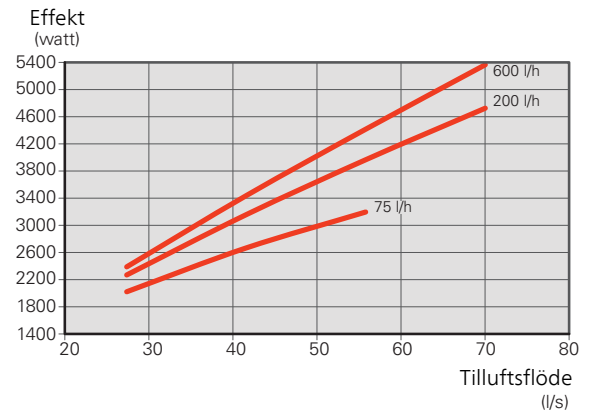

Supply temperature 55°C, DUT -10°C

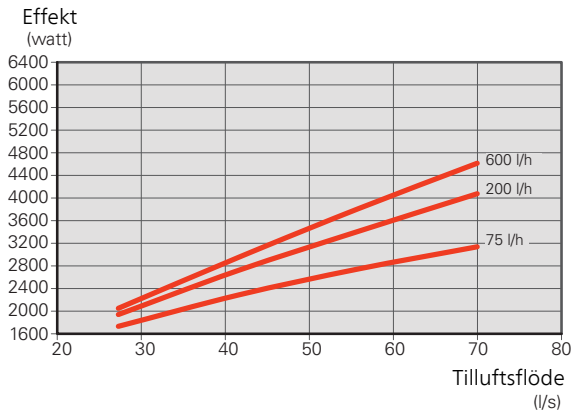

Supply temperature 55°C, DUT -20°C

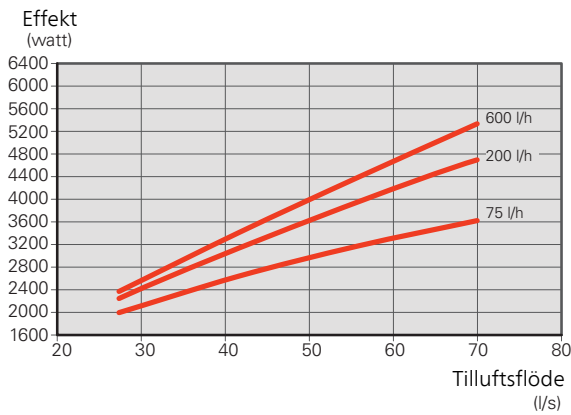

Supply temperature 55°C, DUT -30°C

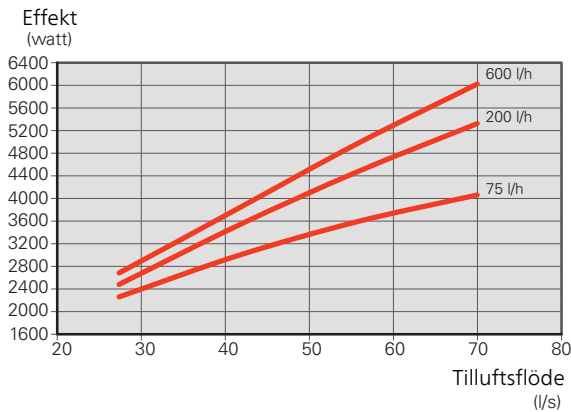

Working range SAM 40

Recommended pressure drop in the system

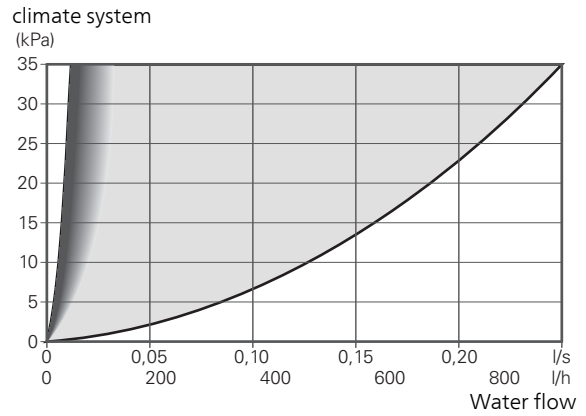

The diagram shows the climate system's required pressure drop. The pressure drop across SAM 40 is the same as that across the climate system that is parallel with SAM 40.

Check that the working point is inside the grey area. If the working point is inside the dark grey area, to the left in the diagram, it can give rise to an oscillating supply air temperature. If there is too low a pressure drop across the climate system that is parallel with SAM 40, there is a risk of ending up in the white area. In this area, there is a risk of too low a water flow through the supply air module and there is then a risk of freezing.

Installation alternative

SAM 40 can be installed in several different ways, some of which are shown below.

More information about the options is available at nibe.eu.

Mounting

Installing on brackets

1. Install SAM 40 on brackets (accessory BAU 10) as illustrated below.
2. Connect heating medium pipes and ventilation ducts.

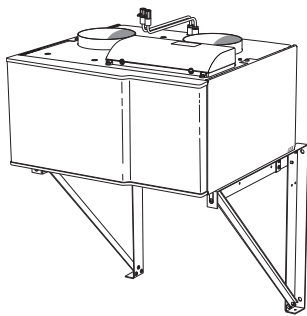

Installing on water heater

VPB 200



Caution

For connection of VPB 200 to F750, docking kit DEW 40 is used.

1. Remove the service cover from VPB 200.
2. Remove the top panel from VPB 200 (installed with 6 screws).
3. Install DEW 40 according to the instructions in the installation manual. The pipes in VPB 200 can be adjusted/replaced in such a way that SAM 40 can easily be installed above VPB 200.

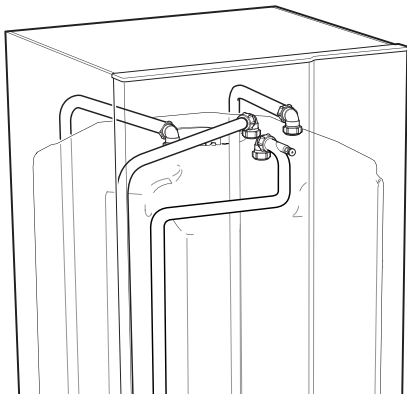

4. Install SAM 40 from the top and slide into position.

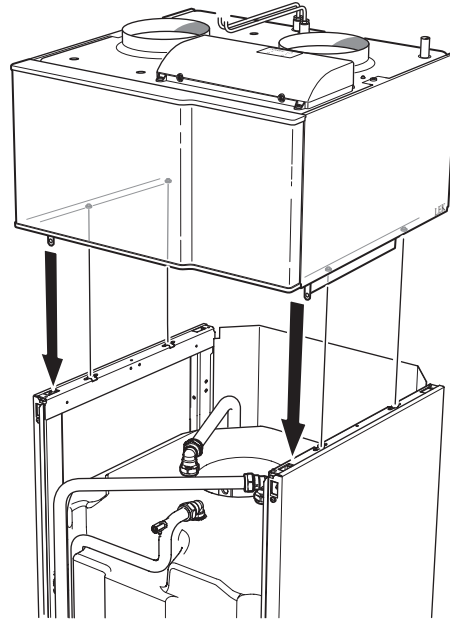

5. Secure SAM 40 with the 2 screws supplied.

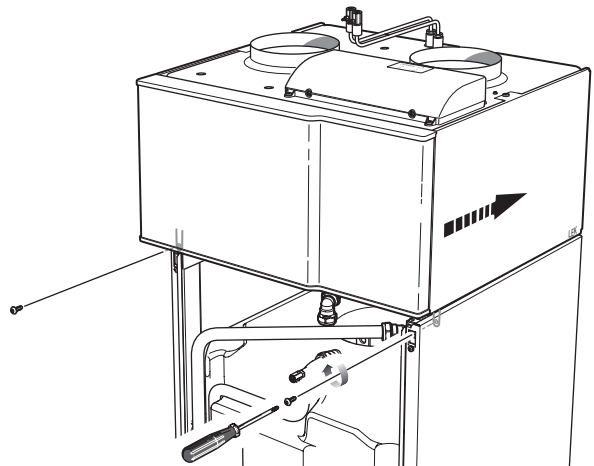

6. Connect heating medium and ventilation pipes.
7. Reinstall the service cover on VPB 200.

AHPS



Caution

For connection of AHPS to F750, docking kit SCA 42 is used.

In order to locate SAM 40 above AHPS, some conversion of AHPS is required. See the Installer Manual for SCA 42 for more information.

Volume vessel

During hot water production and when F750 is defrosting, no energy is supplied to the climate system. For this reason, to achieve satisfactory function of the supply air module, stored energy must be available in the climate system during these operating cases. If there are closed thermostat valves blocking the flow through the radiators/underfloor heating coils, the volume in these cannot be included in the system volume.

If the total volume in the climate system (excluding the heat pump volume) is less than 40 litres, extra system volume, e.g. volume vessel UKV, has to be connected to the supply line after the heat pump.

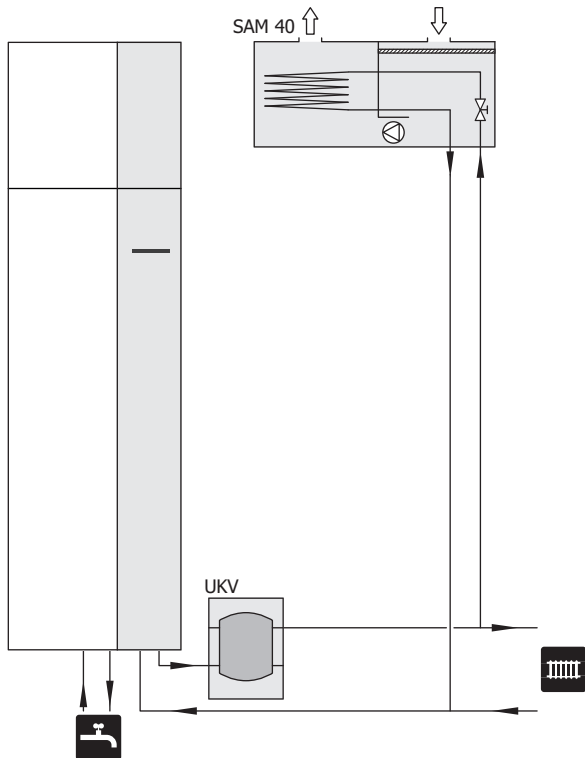

Extra climate system

In buildings with several climate systems that require different supply temperatures, the accessory ECS 40/ECS 41 can be connected. A shunt valve then lowers the temperature to the underfloor heating system, for example.

SAM 40 is connected in parallel with the extra climate system.

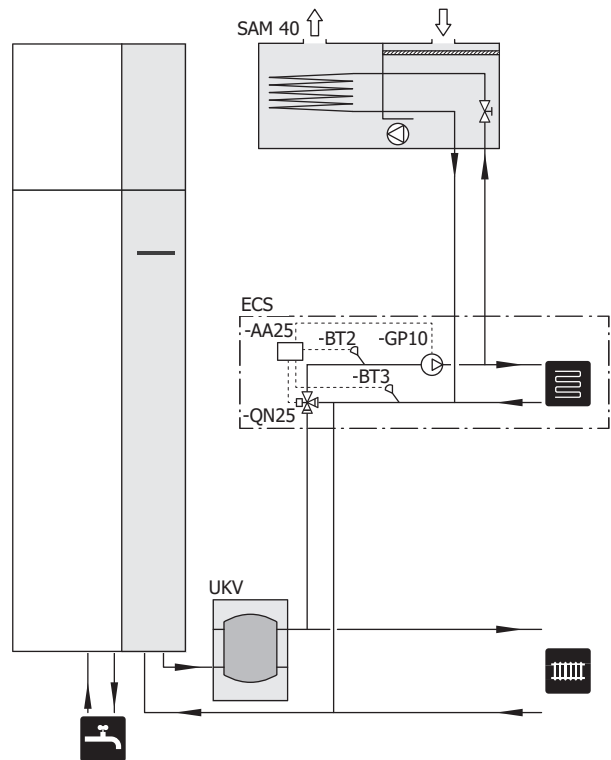

General ventilation connection

- Ventilation installation must be carried out in accordance with current norms and directives.
- Connections must be made via flexible hoses, which should be installed so that they are easy to replace.
- Provision must be made for inspection and cleaning of the duct.
- Make sure that there are no reductions of cross-sectional area in the form of creases, tight bends, etc., since this will reduce the ventilation capacity.
- The air duct system must be a minimum of air tightness class B.
- To prevent fan noise being transferred to the ventilation devices, install silencers in the ducts.
- The outdoor air duct is insulated using diffusion-proof material (at least PE30 or equivalent) along its entire length.
- Ensure that the condensation insulation is fully sealed at any joints and/or at lead-in nipples, silencers, roof cowls or similar.
- The air must be routed to the outdoor air duct through an outer wall grille in the facade. The outer wall grille must be installed so that it is protected from the weather and must be designed so that no rainwater and/or snow can penetrate the facade or follow the air into the duct.
- When positioning the outdoor air and extract air hood/grille, bear in mind that the two air flows must not short circuit to prevent the extract air from being drawn into SAM 40 again.
- When external devices that affect the ventilation are used, for example kitchen fans and stoves, the heat pump must be in operation. There is a risk of freezing at low outdoor temperatures.

Ventilation flow

The supply air flow must be lower than the exhaust air flow to prevent over pressure in the house.

Set the ventilation capacity in the heat pump's menu system (menu 5.1.6).

Adjusting ventilation

To obtain the necessary air exchange in every room of the house, the exhaust air device and the supply air device must be correctly positioned and adjusted and the fans in the heat pump and supply air module adjusted.

Immediately after installation adjust the ventilation so that it is set according to the projected value of the house.

Incorrect adjustment of the ventilation may lead to reduced installation efficiency and thus poorer operating economy, and may cause moisture damage in the building

Dimension and ventilation connections

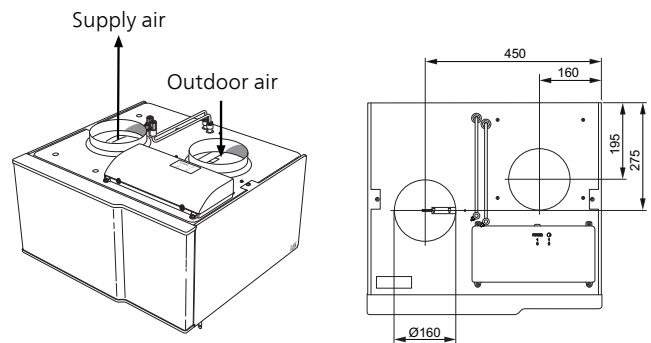

5 Electrical connections

General

All electrical equipment is connected at the factory.

- Disconnect SAM 40 before insulation testing the house wiring.
- For the supply air module wiring diagram, see page 25.
- Signal cables to external connections must not be laid close to high current cables.
- If the supply cable is damaged, only NIBE, its service representative or similar authorised person may replace it to prevent any danger and damage.



NOTE

Electrical installation and service must be carried out under the supervision of a qualified electrician. Electrical installation and wiring must be carried out in accordance with the stipulations in force.

Connections

Connecting to compatible heat pump

The heat pump switch must be moved to position "⏻" and the switch (SF1) on SAM 40 to position 0, before any work can be started.

1. Ensure that the products are completely disconnected from the power source. Remove the front hatch and protective cover to the input card on the heat pump according to the instructions in its Installer's manual.
2. Connect cable W102 to position X4 on the input board (AA3) in the heat pump according to the wiring diagram on page 25. Use the cable lead-in in the heat pump when routing cables.

If several accessories are to be connected or are already installed, the adjacent wiring diagram must be followed.

3. Fix external cable routing.
4. Install the protective cover and the service cover according to the heat pump Installation manual.
5. Connect plug W101.

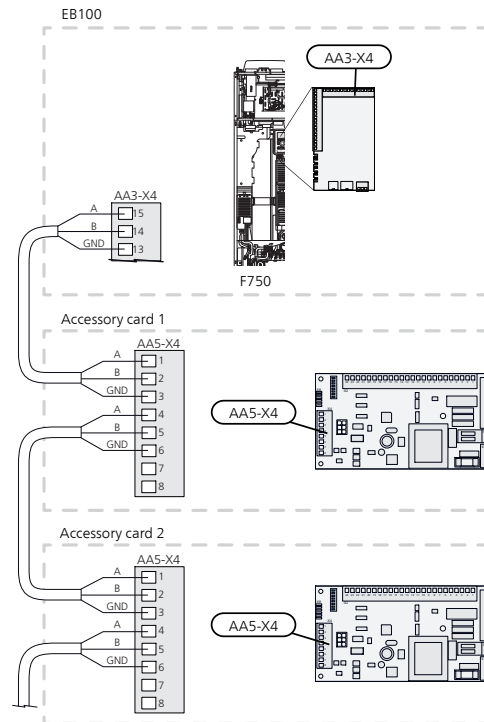

Connection of external frost protection (outdoor air damper)

For connection of external frost protection (outdoor air damper), see the Installer Manual for F750.

DIP switch

The DIP-switch (S2) on the accessory board (AA5) is set in the factory as below.

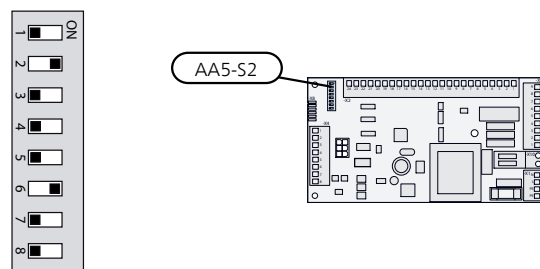

6 Commissioning and adjusting

Preparations

1. Check that the switch (SF1) for the heat pump is in position "⏻".

Filling and venting

Filling the climate system

Fill with water using the filler valve in the heat pump.

Venting the climate system

1. Vent SAM 40 through the vent valve (QM20) and the other climate systems through their respective vent valves.
2. Keep topping up and venting until all air has been removed and the pressure is correct.



Caution

Check that the system has been vented prior to the heating season. Air in the supply air module entails a risk of frost damage in cold weather conditions.

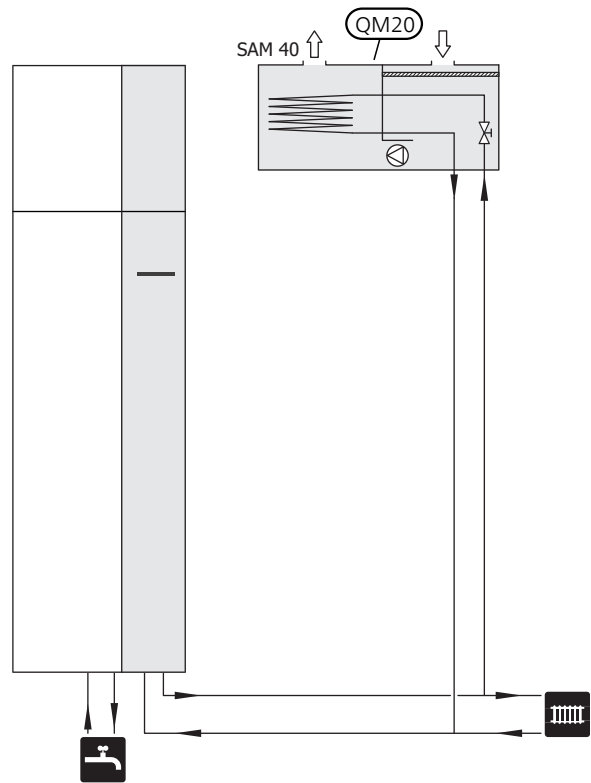

Start-up and inspection

Start-up with compatible heat pump



NOTE

There must be water in the climate system before the switch on the heat pump is set to "I".

1. Set switch (SF1) on SAM 40 in position "1".
2. Set the heat pump's switch (SF1) to "I".
3. Follow the instructions in the start guide in the heat pump display. If the start guide does not start when you start the heat pump, start it manually in menu 5.7.

Commissioning with a compatible heat pump

The first time the installation is started a start guide is started. The start guide instructions state what needs to be carried out at the first start together with a run through of the installation's basic settings.

The start guide ensures that start-up is carried out correctly and cannot be bypassed. The start guide can be started later in menu 5.7.



Caution

As long as the start guide is active, no function in the installation will start automatically.

The guide will appear at each installation re-start until it is deselected on the last page.

Setting the ventilation

Ventilation must be set according to applicable standards. The supply air flow is adjusted to approx. 80% of the exhaust air flow. The setting is made in menu 5.1.6.

Even if ventilation is roughly set at installation it is important that a ventilation adjustment is ordered and permitted.



NOTE

Order a ventilation adjustment to complete the setting.

Ventilation capacity

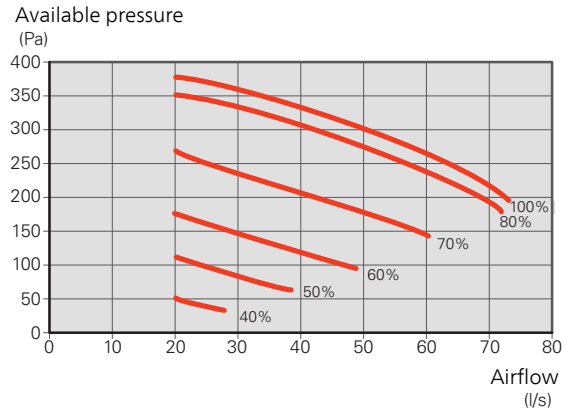

Fan rating

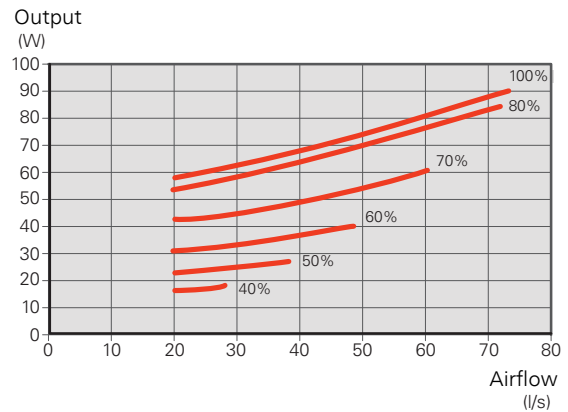

Post-adjustment, venting

Air is initially released from the hot water and venting may be necessary. If gurgling sounds can be heard from the heat pump or climate system, the entire system requires additional venting. See section "Venting the climate system" on page 17 for information about venting.

7 Program settings



Caution

See also the User/Installer manual for the heat pump.

Menu system

If you do not make all settings via the start guide or need to change any of the settings, this can be done in the menu system.

Menu 5.2 -system settings

Activating/deactivating of accessories.

Select: "ext sup air md"

Menu 5.3.9 - ext sup air md

Setting the supply air temperature.

When changing the supply air temperature, the settings for other parts of the climate system may need to be adjusted.

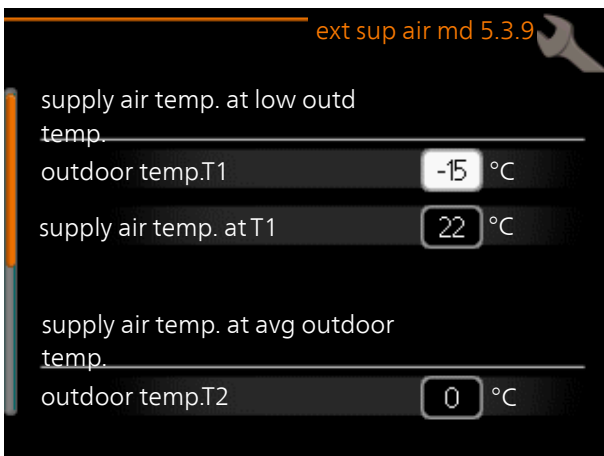

Caution

This accessory may require a program software update in your heat pump.

The heat pump software must be version 8432R2 (F370)/3585R2 (F750) or later.

8 Disturbances in comfort

In most cases, the heat pump notes operational interference (operational interference can lead to disturbance in comfort) and indicates this with alarms and shows action instructions in the display.

Info-menu

All the heat pump measurement values are gathered under menu 3.1 in the heat pump menu system. Looking through the values in this menu can often simplify finding the source of the fault. See help menu or user manual for more information about menu 3.1.

All the heat pump measurement values are gathered under menu 3.1 in the heat pump menu system. Looking through the values in this menu can often simplify finding the source of the fault.

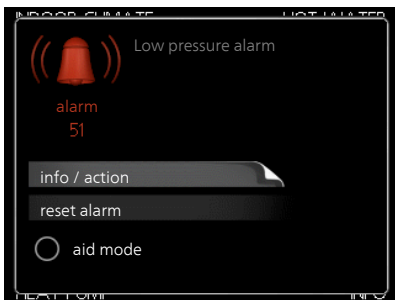

In the event of an alarm, some kind of malfunction has occurred, which is indicated by the status lamp changing from green continuously to red continuously. In addition, an alarm bell appears in the information window.

Alarm

In the event of an alarm with a red status lamp a malfunction has occurred that the heat pump cannot remedy itself. In the display, by turning the control knob and pressing the OK button, you can see the type of alarm it is and reset it. You can also choose to set the heat pump to aid mode.

info / action Here you can read what the alarm means and receive tips on what you can do to correct the problem that caused the alarm.

reset alarm In most cases it is sufficient to select "reset alarm" to correct the problem that caused the alarm. If a green light comes on after selecting "reset alarm", the alarm has been remedied. If a red light is still visible and a menu called "alarm" is visible in the display, the problem causing the alarm remains. If the alarm disappears and then returns, see the troubleshooting section (page Troubleshooting).

aid mode "aid mode" is a type of emergency mode. This means that the heat pump produces heat and/or hot water despite there being some kind of problem. This can mean that the heat pump's compressor is not running. In this case the immersion heater produces heat and/or hot water.

 **NOTE**
To select aid mode an alarm action must be selected in the menu 5.1.4.



Caution

Selecting "aid mode" is not the same as correcting the problem that caused the alarm. The status lamp will therefore continue to be red.

Troubleshooting

If the operational interference is not shown in the display the following tips can be used:

Basic actions

Start by checking the following items:

- That the heat pump is running or that the supply cable to SAM 40 is connected.
- Group and main fuses of the accommodation.
- The property's earth circuit breaker.
- The heat pump's miniature circuit breaker (FA1).
- The heat pump's temperature limiter (FD1).

Low hot water temperature or a lack of hot water

- The heat pump has temporarily prioritised supply air ventilation to prevent too low temperatures in the supply air coil.

Low room temperature

- Incorrect value set in supply air automatic control system.
 - Enter menu 5.3.9 (ext sup air md) and adjust the setting for the supply air temperature.

High room temperature

- Incorrect value set in supply air automatic control system.
 - Enter menu 5.3.9 (ext sup air md) and adjust the setting for the supply air temperature.

Low or a lack of ventilation

- Filter (HQ11) blocked.
 - Clean or replace the filter.
- The ventilation is not adjusted.
 - Order/implement ventilation adjustment.
- Supply air device closed, blocked or throttled down too much.
 - Check and clean the supply air device.
- Check external frost protection (outdoor air damper).

High or distracting ventilation

- Filter (HQ11) blocked.
 - Clean or replace the filter.
- The ventilation is not adjusted.
 - Order/implement ventilation adjustment.

Low supply air temperature

- Air in the heating medium system.
 - Vent SAM 40 using vent valve (QM20).
- Incorrect value set in supply air automatic control system.
 - Enter menu 5.3.9 (ext sup air md) and reduce the setting for the supply air temperature.

High supply air temperature

- Incorrect value set in supply air automatic control system.
 - Enter menu 5.3.9 (ext sup air md) and adjust the setting for the supply air temperature.

9 Accessories

Bracket BAU 10

Wall mounting of SAM 40.

Part no. 067 526

Buffer vessel UKV

UKV 40

Part no. 088 470

Top cabinet

Top cabinet that conceals the ventilation ducts.

Height 245 mm

Height 345 mm

Part no. 067 517

Part no. 067 518

Height 385-635 mm

Part no. 067 519

10 Technical data

Dimensions and setting-out coordinates

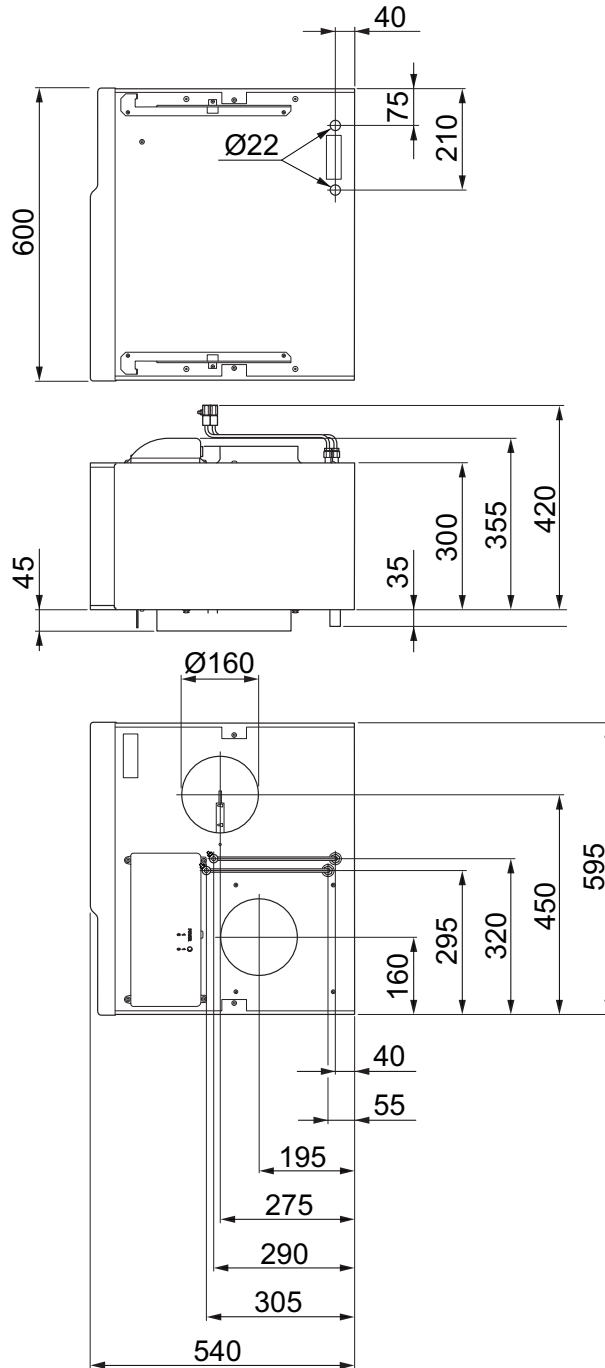

Technical specifications



SAM 40		
<i>Electrical data</i>		
Rated voltage	V	230 V ~ 50 Hz
Drive output control valve	W	1.5
Driving power fan	W	20-175
Enclosure class		IP 21
<i>Heating medium circuit</i>		
Min pressure	MPa/bar	0.05/0.5
Max pressure	MPa/bar	0.25/2.5
<i>Ventilation</i>		
Filter type		ePM1 55%
<i>Sound power level according to EN 12,102</i>		
Sound power level ($L_{v(\Delta)}$) ¹	dB (A)	45-50
<i>Sound pressure levels</i>		
Sound pressure level in the boiler room ($L_{(pA)}$) ²	dB (A)	41-46
<i>Pipe connections</i>		
Heating medium ext Ø	mm	22
Ventilation Ø	mm	160
<i>Miscellaneous</i>		
Width	mm	600
Depth	mm	556
Height	mm	396
Weight	kg	31
Part No.		067 147

¹The value varies with the selected fan curve. For more detailed sound data including sound to channels visit nibe.eu.

² The value may vary with the room's damping capacity. These values apply with 4 dB of damping.

Electrical circuit diagram

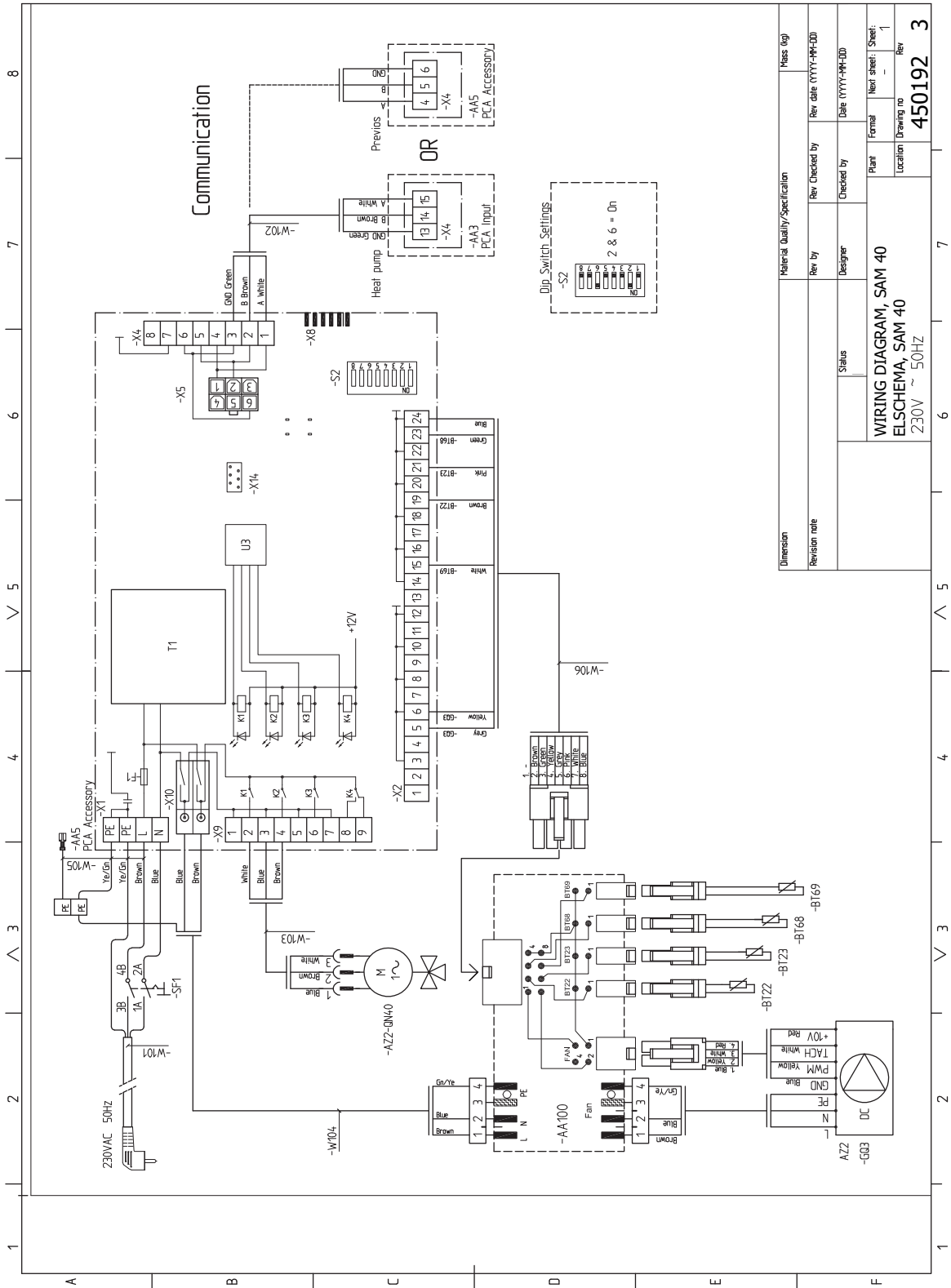

Material Quality/Specification	Mass (kg)	
Revision note	Rev. date (YYYY-MM-DD)	Rev. checked by
Status	Designer	Checked by
Plant	Formal	Rev. sheet
Location	Drawing no	Sheet
	450192	3
	WIRING DIAGRAM, SAM 40	
	ELSICHEMA, SAM 40	
	230V ~ 50Hz	

11 Item register

Item register

A

Accessories, 22
Alarm, 20
Assembly, 6

C

Commissioning and adjusting, 17
 Connecting to heating medium system, 17
 Preparations, 17
 Start-up and inspection, 18
Connecting to heating medium system, 17

D

Delivery and handling, 6
 Removing the covers, 6
Dimensions and pipe connections, 10
Dimensions and setting-out coordinates, 23
Disturbances in comfort, 20
 Alarm, 20
 Manage alarm, 20
 Troubleshooting, 20

E

Electrical circuit diagram, 25
Electrical connections, 16
 Connections, 16
 General, 16

H

Heating medium side, 10
 Output transfer to the supply air, 11

I

Important information, 4
 Marking, 4
 Recovery, 4
 Safety information, 4
 Serial number, 4
 Symbols, 4
Inspection of the installation, 5
Installation alternative
 Two or more climate systems, 14

M

Manage alarm, 20
Marking, 4

O

Output transfer to the supply air, 11

P

Pipe and ventilation connections, 9
 Dimensions and pipe connections, 10
 General pipe connections, 9
 Heating medium side, 10
Preparations, 17

R

Removing the covers, 6

S

Safety information, 4
 Inspection of the installation, 5
 Marking, 4
 Symbols on SAM 40, 4
Serial number, 4
Start-up and inspection, 18
 Setting the ventilation, 18
Symbols, 4
Symbols on SAM 40, 4

T

Technical data, 23
 Dimensions and setting-out coordinates, 23
 Electrical circuit diagram, 25
 Technical Data, 24
Technical Data, 24
The design of the supply air module, 7
 List of components, 8
Transport
 Assembly, 6
Troubleshooting, 20

Contact information

- AT** **KNV Energietechnik GmbH**, Gahberggasse 11, AT-4861 Schörfling
Tel: +43 (0)7662 8963 E-mail: mail@knv.at www.knv.at
- CH** **NIBE Wärmetechnik c/o ait Schweiz AG**, Industriepark, CH-6246 Altishofen
Tel: +41 58 252 21 00 E-mail: info@nibe.ch www.nibe.ch
- CZ** **Druzstevni zavody Drazice s.r.o.**, Drazice 69, CZ - 294 71 Benátky nad Jizerou
Tel: +420 326 373 801 E-mail: nibe@nibe.cz www.nibe.cz
- DE** **NIBE Systemtechnik GmbH**, Am Reiherpfahl 3, 29223 Celle
Tel: +49 (0)5141 7546-0 E-mail: info@nibe.de www.nibe.de
- DK** **Vølund Varmeteknik A/S**, Member of the Nibe Group, Brogårdsvej 7, 6920 Videbæk
Tel: +45 97 17 20 33 E-mail: info@volundvt.dk www.volundvt.dk
- FI** **NIBE Energy Systems OY**, Juurakkotie 3, 01510 Vantaa
Tel: +358 (0)9-274 6970 E-mail: info@nibe.fi www.nibe.fi
- FR** **NIBE Energy Systems France Sarl**, Zone industrielle RD 28, Rue du Pou du Ciel, 01600 Reyrieux
Tel : 04 74 00 92 92 E-mail: info@nibe.fr www.nibe.fr
- GB** **NIBE Energy Systems Ltd**, 3C Broom Business Park, Bridge Way, S419QG Chesterfield
Tel: +44 (0)845 095 1200 E-mail: info@nibe.co.uk www.nibe.co.uk
- NL** **NIBE Energietechniek B.V.**, Postbus 634, NL 4900 AP Oosterhout
Tel: 0168 477722 E-mail: info@nibenl.nl www.nibenl.nl
- NO** **ABK AS**, Brobekkveien 80, 0582 Oslo, Postadresse: Postboks 64 Vollebakk, 0516 Oslo
Tel: +47 23 17 05 20 E-mail: post@abkklima.no www.nibe.no
- PL** **NIBE-BIAWAR Sp. z o. o.** Aleja Jana Pawła II 57, 15-703 BIALYSTOK
Tel: +48 (0)85 662 84 90 E-mail: sekretariat@biawar.com.pl www.biawar.com.pl
- RU** © "EVAN" 17, per. Boynovskiy, RU-603024 Nizhny Novgorod
Tel: +7 831 419 57 06 E-mail: kuzmin@evan.ru www.nibe-evan.ru
- SE** **NIBE AB Sweden**, Box 14, Hannabadsvägen 5, SE-285 21 Markaryd
Tel: +46 (0)433 73 000 E-mail: info@nibe.se www.nibe.se

For countries not mention in this list, please contact Nibe Sweden or check www.nibe.eu for more information.

NIBE AB Sweden
Hannabadsvägen 5
Box 14
SE-285 21 Markaryd
info@nibe.se
www.nibe.eu



531368